

## MODEL RW300A

Up To 40,000-POUND LINEPULL

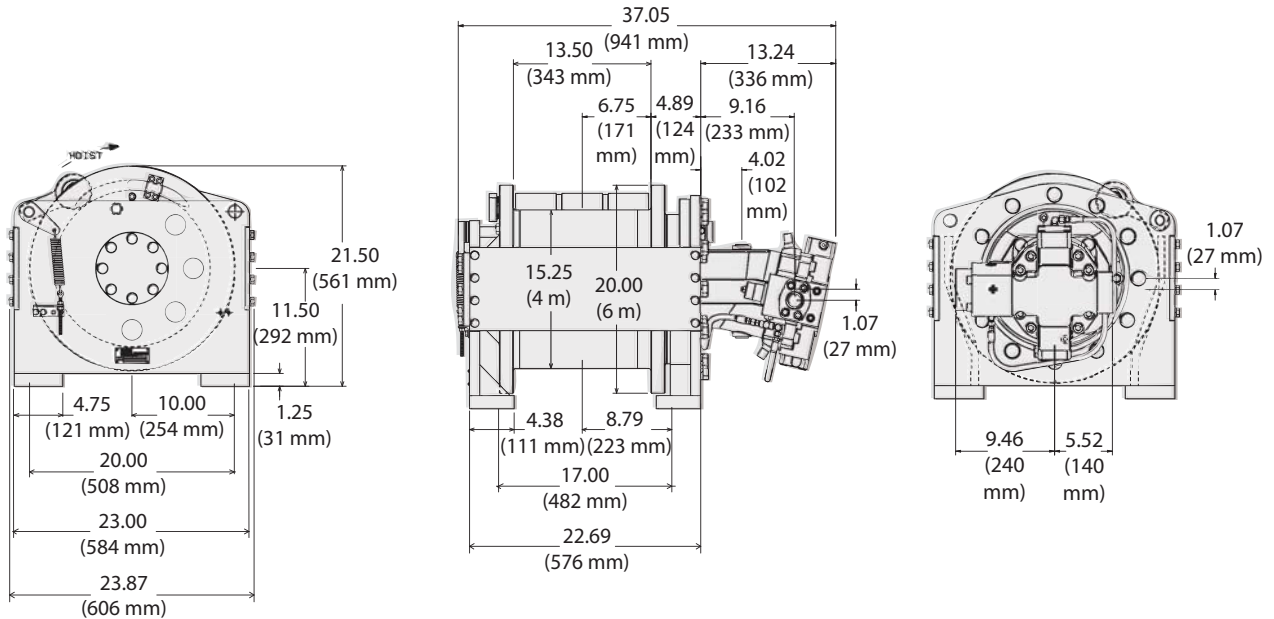

- 40,000 lb (18,144 kg) First-layer line pull
- Variable Piston Motor
- 69:1 Ratio
- Weight 1,390 lb (630 kg)

### RW300A 69BS-05711 - LOW SPEED

8.38 cu in. Motor (137.3 cc)  
 4699 PSI (324 bar) @ 70 gpm (264.9 lpm)  
 Wire Rope Diameter: 7/8 in. (22 mm)

	LINE PULL		LINE SPEED		ROPE CAPACITY	
	LB	KG	FPM	MPM	FT	M
1	40,000	18,144	109	33	58	17
2	36,080	16,365	121	37	122	37

### RW300A 69BS-05711 - HIGH SPEED

4.06 cu in. Motor (66.5 cc)  
 4700 PSI (324 bar) @ 70 gpm (264.9 lpm)  
 Wire Rope Diameter: 7/8 in. (22 mm)

	LINE PULL		LINE SPEED		ROPE CAPACITY	
	LB	KG	FPM	MPM	FT	M
1	17,620	7,992	227	69	58	17
2	15,900	7212	251	77	122	37