

MODEL 50B-PS WINCH for CASE 1150H (Power Shift) TRACTORS

CARCO®

for CASE

SPECIFICATIONS

CABLE DRUM SIZE

Barrel Diameter	10 in.	(254 mm)
Flange Diameter	19 7/8 in.	(504 mm)
Barrel Length	13 in.	(330 mm)

MAXIMUM CABLE CAPACITY & FERRULE

3/4 in. (19 mm)	. . .400 ft (122 m)	Ferrule P/N 29424 (Recomm.)
7/8 in. (22 mm)	. . .290 ft (88 m)	Ferrule P/N 29425 (Optional)

HYDRAULIC SYSTEM

Oil Capacity66 qts	(63 L)
Hydraulic Pressure for Winch Control400 psi	(2,760 kPa)
Hydraulic Pump is Gear Type		
Accumulator is Spring-Type		
Applied Weight, without cable or oil2,600 lbs	(1,180 kg)

MODEL 50B-PS DESCRIPTION

- Internal Hydraulic System with Gear Type Pump, Pressure Circuit Filtration and Maintenance-Free Spring-Type Accumulator
- Single Lever Push-Pull Cable Control of Hydraulically Actuated Multi-Disc Wet Clutches and Brake; Equal Speeds - Forward and Reverse
- Rigid Cast Nodular Iron Case with Pin-On Fairlead Mounting Lugs and Heavy-Duty Rigid Draw Bar.

OPTIONS

- Free Spool Drum
- Gear Ratios
- 3 Roller Fairlead
- 4 Roller Fairlead

GEAR RATIO

Winch Overall Ratio:	
Standard Speed85.3:1

Dimensions shown are
inches
(mm)

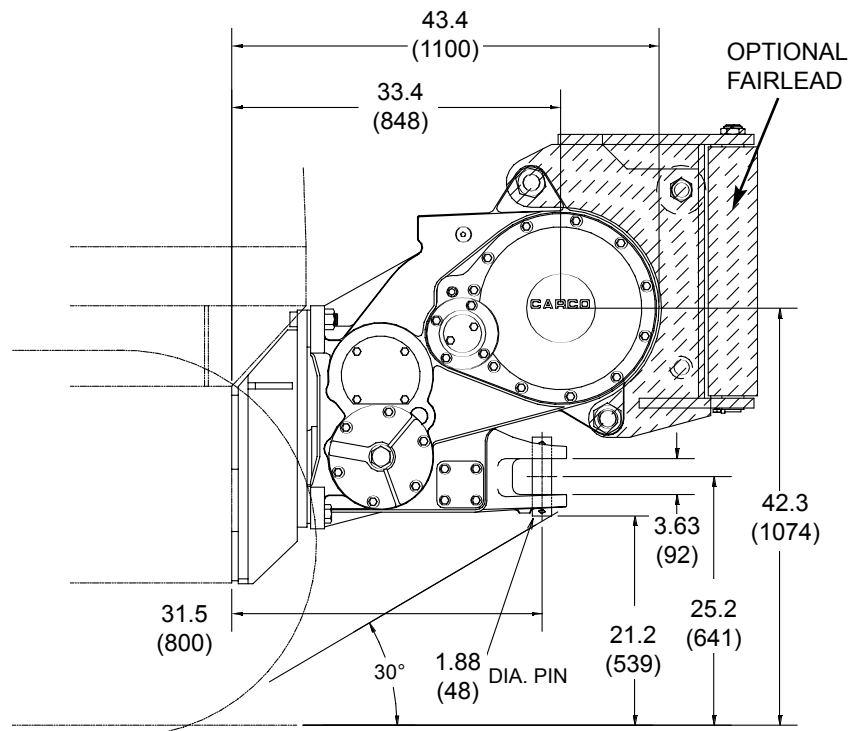

PACCAR WINCH DIVISION

P.O. BOX 547 BROKEN ARROW, OK U.S.A. 74013
PHONE (918) 251-8511 FAX (918) 259-1575

www.paccarwinch.com

Winch line pull and line speed based on specifications noted below, with 0.75 inch (19 mm) diameter wire rope. Performance data shown is theoretical and calculated at 93% efficiency.

NOTE: These tractors are capable of producing input torque to the winch which can result in line pulls in excess of the maximum rated line pull. For pulls over the maximum rating, a multipart line and sheave block must be used.

STANDARD SPEED PERFORMANCE MODEL 50B-PS (TRACTOR PTO IN HIGH RANGE)

1150H			
	Tractor Rating	119 hp @ 2,000 rpm	89 kW @ 2,000 rpm
Bare Drum	Rated Linepull	55,750 lbs	25,290 kg
	Maximum Linepull	89,800* lbs	40,733* kg
	Rated Linespeed	50 fpm	15 mpm
	Maximum Linespeed	90 fpm	27 mpm
Full Drum	Rated Linepull	31,340 lbs	14,220 kg
	Maximum Linepull	68,940 lbs	31,270 kg
	Rated Linespeed	88 fpm	27 mpm
	Maximum Linespeed	160 fpm	49 mpm

STANDARD SPEED PERFORMANCE MODEL 50B-PS (TRACTOR PTO IN LOW RANGE)

1150H			
	Tractor Rating	119 hp @ 2,000 rpm	89 kW @ 2,000 rpm
Bare Drum	Rated Linepull	74,340 lbs	33,720 kg
	Maximum Linepull	89,800* lbs	40,733* kg
	Rated Linespeed	37 fpm	11 mpm
	Maximum Linespeed	62 fpm	19 mpm
Full Drum	Rated Linepull	41,780 lbs	18,950 kg
	Maximum Linepull	89,800* lbs	40,733* kg
	Rated Linespeed	66 fpm	20 mpm
	Maximum Linespeed	110 fpm	34 mpm

* Maximum line pull limited by breaking strength of optional size 0.875 inch (22 mm) IWRC IPS wire rope.