



WARN Industrial Winch

Model	Part Number	Motor Type
Series 12-A-48 Hydraulic Winch Manual Clutch	30285	Hydraulic 4.9 ci (80 cc)

The Series 12 hydraulic winch features a 2 stage planetary gear train with a total reduction of 36:1. This winch uses a heavy duty automatic disc brake and a locking clutch lever. The 4" (102mm) steel drum provides excellent durability for the wire rope. Designed to meet SAE J706 and CE standards.



Accessories

Description:	Part Number
Wire Rope Tension Plate 10"	31149
Fairlead Black 10"	24336
Fairlead Chrome 10"	30859
Remote Clutch Mechanical	38316
Remote Clutch Air	71370
Wire Rope Assembly 7/16"x100' EIPS	23678

Engineering Data			
Rated Pulling Force:	12000	lbf	5443 kgf
Drum Barrel Diameter:	4.00	in	102 mm
Drum Flange Diameter:	8.24	in	209 mm
Distance Between Flanges:	9.95	in	253 mm
Recommended Maximum Wire Rope Diameter:	1/2	in	12.7 mm
Recommended Minimum Wire Rope Breaking Strength:	20400	lbf	9253 kgf
Approximate Shipping Weight:	85.5	lb	38.8 kg
Duty Cycle (intermittent per SAE J706 section 6.2):	350	ft	107 m
Mounting Bolt Torque:	35 - 40	ft*lb	47 - 54 N*m
Maximum Layers of Wire Rope:	4 (with 7/16" dia rope)		
Gear Reduction:	36:1		
Brake Type:	Disk		
Contactor / Remote Type:	N/A		

Drum Rotation

Viewed from Motor End

Standards Compliance

- SAE J706
- CE Machinery Directive 98/37/EC and 2006/42/EC

Performance By Layer- 7/16" (11.1 mm) dia. rope

Drum Layer	Line Load *			Line Speed 10 GPM		Line Speed 15 GPM		Drum Capacity	
	lbf	kgf	kN	ft/min	m/min	ft/min	m/min	ft	m
1	12000	5443	53.4	15.2	4.6	21.8	6.6	23	7.0
2	10023	4546	44.6	18.2	5.5	26.1	8.0	51	15.5
3	8606	3904	38.3	21.2	6.5	30.4	9.3	84	25.6
4	7539	3420	33.5	24.2	7.4	34.7	10.6	121	36.9

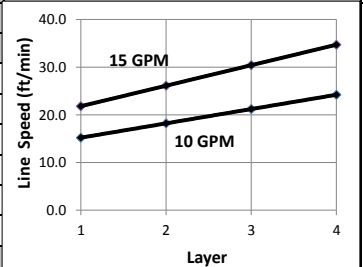

* Never exceed the Rated Pulling Force. Installation of a Rated Capacity Limiter is recommended.

First Layer Performance

Line Load		Pressure Drop at 10 GPM		Pressure Drop at 15 GPM		Duty Cycle
lbf	kgf	psi	BAR	psi	BAR	min/10min
0	0	234	16.1	376	25.9	N/A
2000	907	505	34.8	640	44.1	N/A
4000	1814	777	53.6	918	63.3	N/A
6000	2722	1076	74.2	1193	82.3	N/A
8000	3629	1367	94.3	1503	103.6	N/A
10000	4536	1707	117.7	1784	123.0	N/A
12000	5443	2127	146.7	2163	149.1	N/A

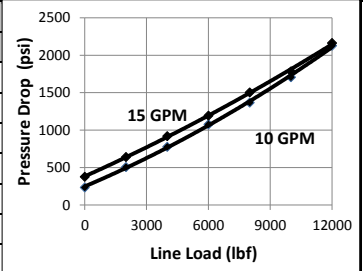

WARN INDUSTRIES, INC
Industrial Products

Customer Service (North America): 1.800.543.9276
Customer Service (International): 1.503.722.3008
FAX: 1.503.722.3000 www.warn.com

12900 S.E. Capps Road,
Clackamas, OR USA 97015



WARN Industrial Winch

Model	Part Number	Motor Type
Series 12-A-48 Hydraulic Winch Manual Clutch	30285	Hydraulic 4.9 ci (80 cc)

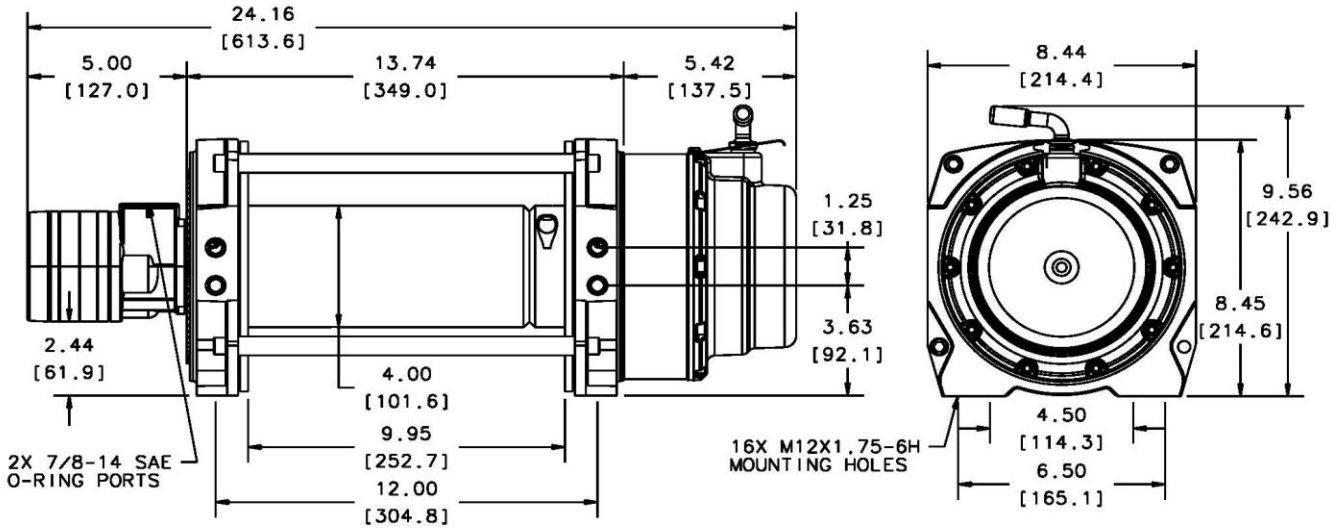

Motor / Contactor may be rotated in 90 degree increments. Clutch housing may be rotated in 72 degree increments.

Units are given in inches [millimeters], unless otherwise specified

Recommended Mounting- Always Observe Correct Drum Rotation			Hydraulic System Specifications	
Pull from bottom of winch	Pull from bottom of winch	Pull from top of winch	Maximum System Pressure:	1950 psi 135 BAR
			Maximum Motor Pressure Drop:	2163 psi 149 BAR
Feet down	Feet forward	Feet forward	Maximum Rated Input Flow:	15 GPM 57 LPM
Pull from top of winch	Pull from top of winch	Pull from top of winch	Control Valve Type:	3-position, 4-way, closed center, spring return (cylinder spool)
			Control Valve Schematic	
Feet down without angle brace	Feet down with angle brace	Angle Braces Only		
			Note: Drum rotates clockwise with Port A pressurized when viewed from gearbox end.	

WARN INDUSTRIES, INC
Industrial Products

Customer Service (North America): 1.800.543.9276
Customer Service (International): 1.503.722.3008
FAX: 1.503.722.3000 www.warn.com

12900 S.E. Capps Road,
Clackamas, OR USA 97015