



WARN Industrial Winch

Model	Part Number	Motor Type
Series 9-A-48 Hydraulic Winch Manual Clutch	30281	Hydraulic 4.9 ci (80 cc)

The Series 9 hydraulic winch features a 2-stage planetary gear train with a total reduction of 27:1. This winch uses a heavy duty automatic disc brake and a locking clutch lever. The 4" (102mm) steel drum provides excellent durability for the wire rope. Designed to meet SAE J706 and CE standards.



Accessories

Description:	Part Number
Wire Rope Tension Plate 10"	31149
Fairlead Black 10"	24336
Fairlead Chrome 10"	30859
Remote Clutch Mechanical	38316
Remote Clutch Air	71370
Wire Rope Assembly 3/8"x125' EIPS	23674

Engineering Data			
Rated Pulling Force:	9000	lbf	4082 kgf
Drum Barrel Diameter:	4.00	in	102 mm
Drum Flange Diameter:	8.24	in	209 mm
Distance Between Flanges:	9.95	in	253 mm
Recommended Maximum Wire Rope Diameter:	1/2	in	12.7 mm
Recommended Minimum Wire Rope Breaking Strength:	15,100	lbf	6849 kgf
Approximate Shipping Weight:	80.0	lb	36.3 kg
Duty Cycle (intermittent per SAE J706 section 6.2):	1034	ft	315 m
Mounting Bolt Torque:	35 - 40	ft*lbf	47 - 54 N*m
Maximum Layers of Wire Rope:	4 (with 3/8" dia. rope)		
Gear Reduction:	27:1		
Brake Type:	Disk		
Contactor / Remote Type:	N/A		

Drum Rotation

Viewed from Motor End

Standards Compliance

- SAE J706
- CE Machinery Directive 98/37/EC and 2006/42/EC

Performance By Layer- 3/8" (9.5 mm) dia. rope

Drum Layer	Line Load *			Line Speed 10 GPM		Line Speed 15 GPM		Drum Capacity	
	lbf	kgf	kN	ft/min	m/min	ft/min	m/min	ft	m
1	9000	4082	40.0	19.9	6.1	28.5	8.7	25	7.6
2	7364	3340	32.8	23.8	7.3	34.1	10.4	54	16.5
3	6231	2826	27.7	27.7	8.4	39.8	12.1	88	26.8
4	5400	2449	24.0	31.7	9.7	45.4	13.8	126	38.4

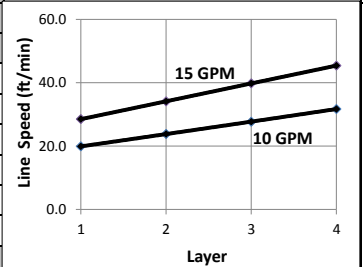

* Never exceed the Rated Pulling Force. Installation of a Rated Capacity Limiter is recommended.

First Layer Performance

Line Load		Pressure Drop at 10 GPM		Pressure Drop at 15 GPM		Duty Cycle
lbf	kgf	psi	BAR	psi	BAR	min/10min
0	0	242	16.7	358	24.7	N/A
1500	680	494	34.0	622	42.9	N/A
3000	1361	800	55.1	887	61.1	N/A
4500	2041	1110	76.5	1134	78.2	N/A
6000	2722	1388	95.7	1405	96.9	N/A
7500	3402	1710	117.9	1735	119.6	N/A
9000	4082	2050	141.3	2027	139.8	N/A

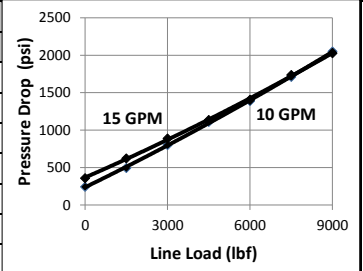

WARN INDUSTRIES, INC
Industrial Products

Customer Service (North America): 1.800.543.9276
Customer Service (International): 1.503.722.3008
FAX: 1.503.722.3000 www.warn.com

12900 S.E. Capps Road,
Clackamas, OR USA 97015



WARN Industrial Winch

Model	Part Number	Motor Type
Series 9-A-48 Hydraulic Winch Manual Clutch	30281	Hydraulic 4.9 ci (80 cc)

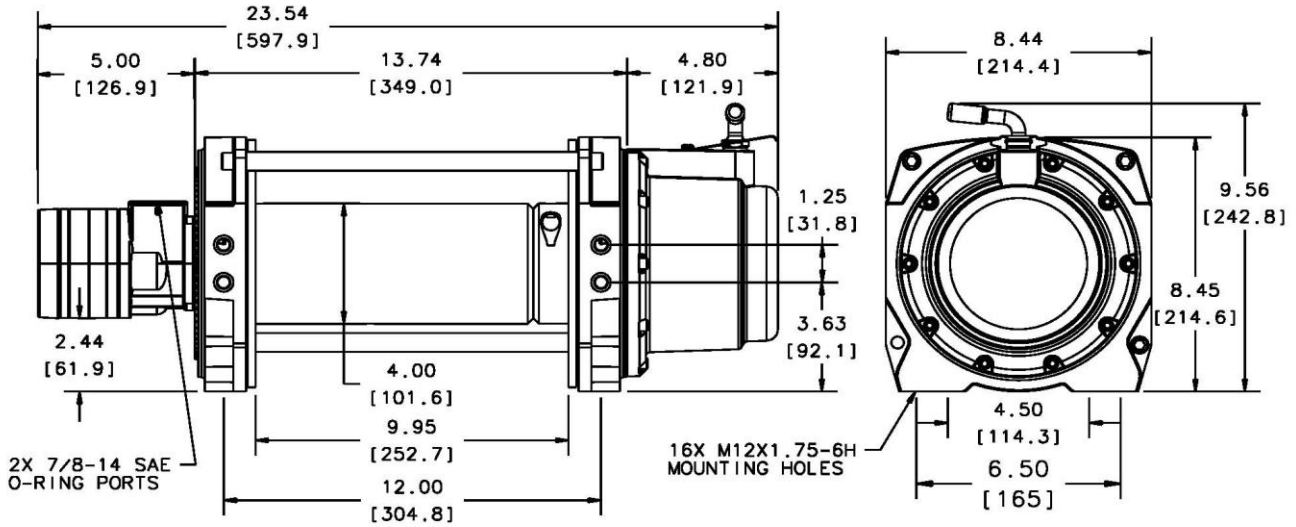

Motor / Contactor may be rotated in 180 degree increments. Clutch housing may be rotated in 72 degree increments.

Units are given in inches [millimeters], unless otherwise specified

Recommended Mounting- Always Observe Correct Drum Rotation			Hydraulic System Specifications		
Pull from bottom of winch	Pull from bottom of winch	Pull from top of winch	Maximum System Pressure:	2200 psi	152 BAR
			Maximum Motor Pressure Drop:	2027 psi	140 BAR
Feet down	Feet forward	Feet forward	Maximum Rated Input Flow:	15 GPM	57 LPM
Pull from top of winch	Pull from top of winch	Pull from top of winch	Control Valve Type:	3-position, 4-way, closed center, spring return (cylinder spool)	
			Control Valve Schematic		
Feet down without angle brace	Feet down with angle brace	Angle Braces Only			
			Note: Drum rotates clockwise with Port A pressurized when viewed from gearbox end.		

WARN INDUSTRIES, INC
Industrial Products

Customer Service (North America): 1.800.543.9276
Customer Service (International): 1.503.722.3008
FAX: 1.503.722.3000 www.warn.com

12900 S.E. Capps Road,
Clackamas, OR USA 97015