

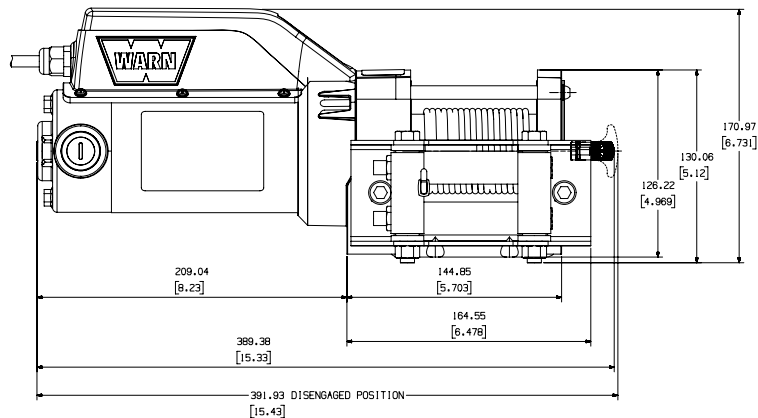

AC1500 WINCH

Part Number: 85330
Rated Line Pull: 1500 lbs. (680kgs)
Motor: 120V AC, 0.8 hp (600W) Permanent Magnet
Controls: Pendant Remote
Gear train: Planetary, Differential Planetary
Gear Ratio: 261:1
Clutch (Freespool): Pull and Turn
Brake: Self Braking Transmission
Drum diameter/length: 2.0"/3.3" (52mm/84mm)
Kit Shipping Weight: 29.1 lbs. (13.2 kgs)
Rope: Galvanized Steel Wire, Ø 3/16" x 43' (Ø 4.8mm x 13.1 m)
Fairlead: Roller
Power: 120V AC, GFCI
Duty Cycle: Intermittent
Finish: Steel Grey Powder Coat
Warranty: One Year
Mounting Bolt Pattern: 3.1" x 2.5" (78.8mm x 63.5mm)
Mounting Bolt: 4 x 8mm
Winch Dimensions: 15.42" L x 5.7" D x 6.73" H (39.2cm L x 14.5cm D x 17.1cm H)
Winch Weight: 28 lbs. (12.7 kgs)



PERFORMANCE DATA (specs are based on first layer of drum)

Load Lbs. (kg)	Line speed FT./min (M/min)	Motor Current, Amps (At 120 VAC)
0 (0)	9.7 (2.9)	0.5
250 (113)	7.7 (2.3)	1.8
500 (227)	6.9 (2.1)	3.1
750 (340)	6.1 (1.8)	4.4
1000 (454)	5.4 (1.6)	5.8
1250 (568)	4.9 (1.5)	7.3
1500 (680)	4.4 (1.3)	9.1

DUTY CYCLE *

Load lbs(kgs)	Run Time	Distance ft.(m)	Cool Time (min)
0	30 min	303 (92.4)	20
750 (340)	7.0 min	52 (15.8)	20
1500 (680)	3.0 min	16 (4.8)	20

* Duty Cycle times are for a one hour duration. If run plus cool time exceeds one hour, cool time must double.

ELECTRICAL DIAGRAM

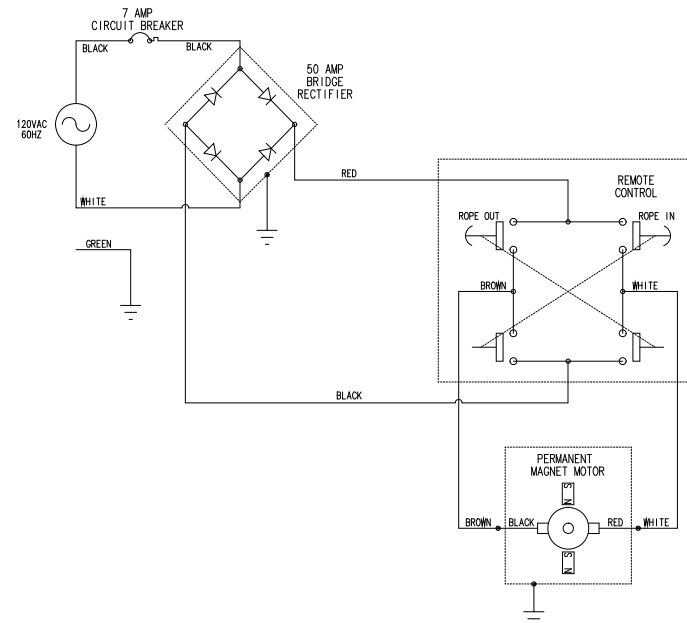

SERVICE INSTRUCTIONS

Should you encounter a problem during installation or operation of your winch, please follow these steps toward resolving the problem:

1. Refer to your operator's guide and installation instructions. It has illustrations and detailed information on the installation and safe and proper operation of your winch. It also includes a replacement parts list and assembly diagrams. If you are unable to resolve the problem, then go to step 2.
2. Contact your dealer where you purchased your winch. If, after discussing the problem with their parts and service staff, you are still unable to resolve the problem then go to step 3.
3. Call an Authorized WARN Service center from the list provided on the back of the warranty sheet included with the product. When calling, please have the following information available: winch model number and purchase date, make, model and year of vehicle.
4. If you are unable to resolve the problem to your satisfaction, please call Warn Industries Customer Service at: 1-800-543-9276. When calling, please have the following information available: winch model number and purchase date, make, model and year of vehicle. You may also contact Warn Industries by visiting our website: www.warn.com

WINCH SERVICE KITS

Kit PN	Items in Kit
86480	1, 2, 3, 4, 38
82644	4, 5, 6, 7, 38
82645	6, 7
82646	8, 9, 10, 11, 12, 13, 14, 15, 16, 17, 18, 19, 20, 21, 22
82647	23, 26
82648	24, 25, 42
86479	28
82650	26, 27, 29
82656	31
28929	30, 32, 33
69645	34
39557	34, 35
82654	36
82655	37, 22

