

# AHSU3 / AMSU3

## 10,000 LB First Layer Line Pull

# BRADEN®

### DIMENSIONAL INFORMATION

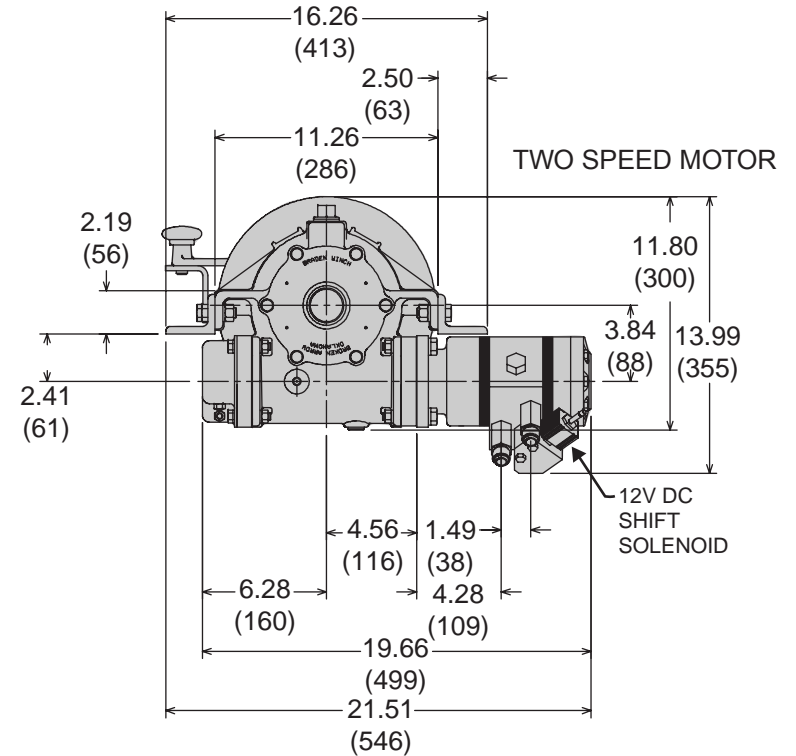
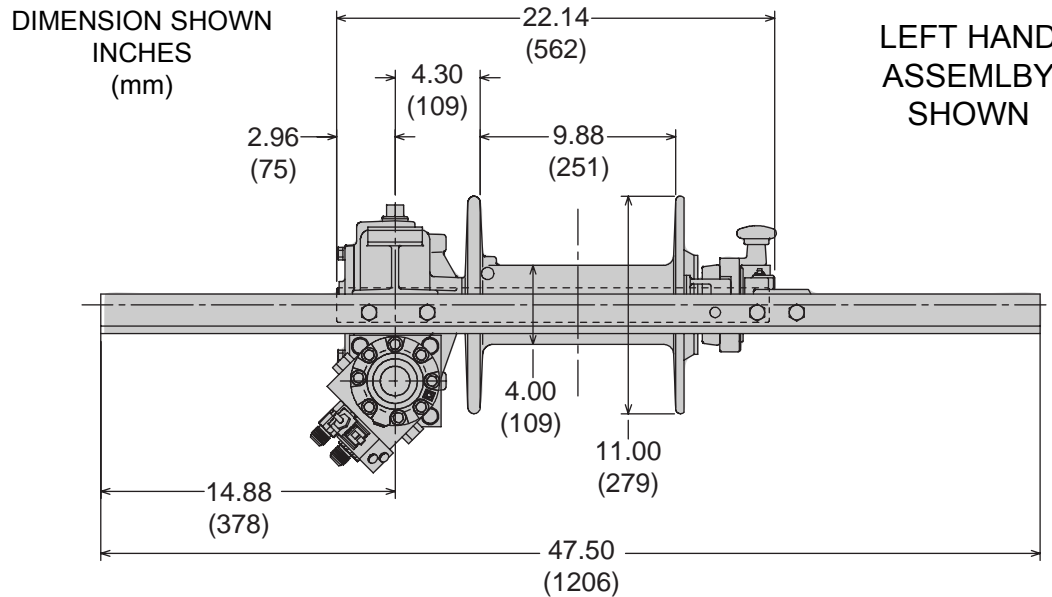

- Tested in compliance with SAE Specification J706.
- Rugged and compact design.
- Adjustable dry band type worm brake.
- High strength aluminum bronze worm gear for increased pulling power and long gear life.
- Freespool clutch with negative draft jaws for positive engagement under load.
- Automatic drag brake helps prevent drum from back spinning when in freespool mode.

SINGLE SPEED MOTOR

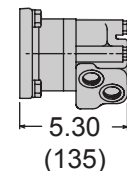

MECHANICAL DRIVE

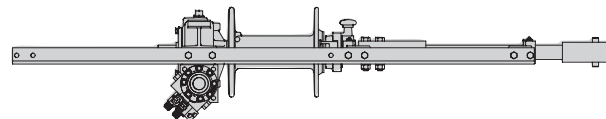
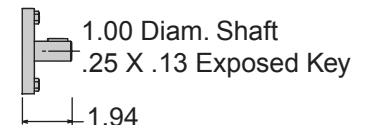

OPTIONAL EXTENSION SHAFT MODELS  
SEE LIT2029 FOR SPECIFICATIONS

### PACCAR WINCH DIVISION

P.O. Box 547 Broken Arrow, Oklahoma 74013  
PHONE: (918) 251-8511 FAX: (918) 259-1575  
[www.paccarwinch.com](http://www.paccarwinch.com)

**WIRE ROPE CAPACITY**

ROPE SIZE	LAYER																	
	1		2		3		4		5		6		7		8		9	
in.	ft	(m)	ft	(m)	ft	(m)	ft	(m)	ft	(m)	ft	(m)	ft	(m)	ft	(m)	ft	(m)
1/2	21	6.4	47	14.3	80	24.4	115	35.1	155	47.2	200	61.0	250	76.2				
7/16	24	7.3	53	16.2	85	25.9	125	38.1	170	51.8	215	65.5	260	79.2	325	99.1		
3/8	28	8.5	60	18.3	100	30.5	135	41.1	185	56.4	235	71.6	290	88.4	350	106.7	420	128.0

WIRE ROPE CAPACITY IS 90% OF THEORITICAL.

**NOTES**

Specifications are subject to change without notification and without incurring obligation.

Pressure and flow shown are the maximum allowable for the particular combination of winch, ratio, motor and drum.

Specifications in this publication are theoretical and may vary depending on hydraulic system, environment, etc.

Line pulls are maximum ratings for the winch only.

Wire rope ratings may be lower than the the winch rating.

Consult the wire rope manufacturer for ratings.

**PERFORMANCE INFORMATION**

**Single Speed Performance**

9.6 cu in. (157 cc)

2500 Δ psi (172 Δ bar) @ 18 gpm (68 lpm)

MECHANICAL REQUIREMENTS:				
Static Input Torque		Dynamic Input Torque		Max Input
lb-in	N-m	lb-in	N-m	RPM
2,770	313	2,000	226	400

LAYER	1/2 in. WIRE ROPE					
	LINE PULL		LINE SPEED		ROPE CAPACITY	
	(lbs)	(kg)	(fpm)	(mpm)	(ft)	(m)
1	10,000	4,545	16	4.9	21	6.4
2	8,200	3,727	20	6.1	47	14.3
3	6,900	3,136	24	7.3	80	24.4
4	6,000	2,727	27	8.2	115	35.1
5	5,300	2,409	31	9.5	155	47.3
6	4,700	2,136	34	10.4	200	61.0
7	4,300	1,954	38	11.6	250	76.3

**2-Speed Performance**

10.8/5.4 cu in. (177/89 cc)

1,800 Δ psi (124 Δ bar) @ 22 gpm (83 lpm)

Layer	Low Speed				High Speed			
	LINE PULL		LINE SPEED		LINE PULL		LINE SPEED	
	(lbs)	(kg)	(fpm)	(mpm)	(lbs)	(kg)	(fpm)	(mpm)
1	10,000	4,500	17	5.1	4,500	2,000	34	10.2
2	8,200	3,700	21	6.3	3,700	1,700	42	12.6
3	6,900	3,100	25	7.5	3,100	1,400	78	23.4
4	6,000	2,700	28	8.4	2,700	1,200	113	33.9
5	5,300	2,400	32	9.6	2,400	1,100	158	47.4
6	4,700	2,100	36	10.8	2,100	900	207	62.1
7	4,300	1,900	40	12.0	1,900	900	262	78.6

**⚠ WARNING ⚠**

A minimum of 5 wraps of wire rope must be left on the drum to prevent the load from being supported by the wire rope anchor alone. Since the wire rope anchor is not designed to hold the rated load, failure to leave 5 wraps of wire rope on the drum could cause the load to drop, which could result in property damage, personal injury or death.

**PERFORMANCE FORMULAS**

**LINE PULL AT LOWER PRESSURE**

$$\frac{\text{YOUR SYSTEM PRESSURE}}{\text{MAXIMUM PRESSURE (FROM CHART)}} \times \text{LINE PULL FROM CHART} = \text{LINE PULL ESTIMATE}$$

**LINE SPEED AT LOWER FLOW**

$$\frac{\text{YOUR SYSTEM FLOW}}{\text{MAXIMUM FLOW (FROM CHART)}} \times \text{LINE SPEED FROM CHART} = \text{LINE SPEED ESTIMATE}$$

**ENGINEERING DATA**

Worm Gear Ratio.....29:1  
 Oil Capacity.....0.75 pints  
 Input Shaft Diameter.....1 in. (25.40 mm)  
 Weight - (Winch Only).....158 lbs. (72 kg)

**⚠ WARNING ⚠**

The products described herein are neither designed nor intended for use or application to equipment used in lifting or moving of persons.