

• Gearmatic®

**HYDRAULIC
WINCH**

GH50

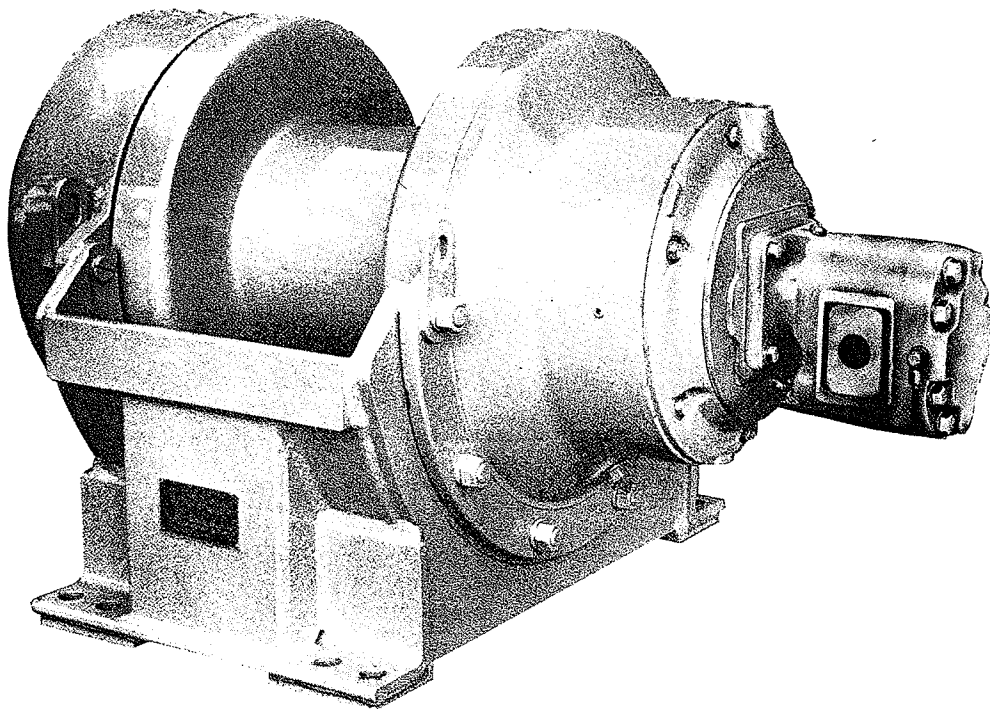

- EQUAL SPEED
- OPTIONAL FREE FALL
- OPTIONAL DRUM SIZES
- OPTIONAL FINAL DRIVE RATIOS

GEARMATIC GH50 FEATURES

The GH50 is available as an equal speed winch with line pulls up to 44,000 lbs., and line speeds up to 191 fpm. Two single speed and one two speed hydraulic motor, along with 8 optional drum sizes and three final drive ratios allow the GH50 to be tailored to the needs of your specific application. Free fall is offered as emergency release, controlled free fall, or both.

This highly efficient winch is extremely compact with totally sealed planet gearing and automatic disc brake. All components run in oil with no need for service adjustments. The externally mounted motor provides the ability to match the winch to the hydraulic system.

Through the support of a worldwide distributor network, the GH50 may be adapted to applications in almost every industry. This hydraulic winch meets OSHA and API requirements for the hydraulic crane industry. The GH50 represents the latest in design technology for hydraulic winches and further supports the Gearmatic reputation for quality and reliability.

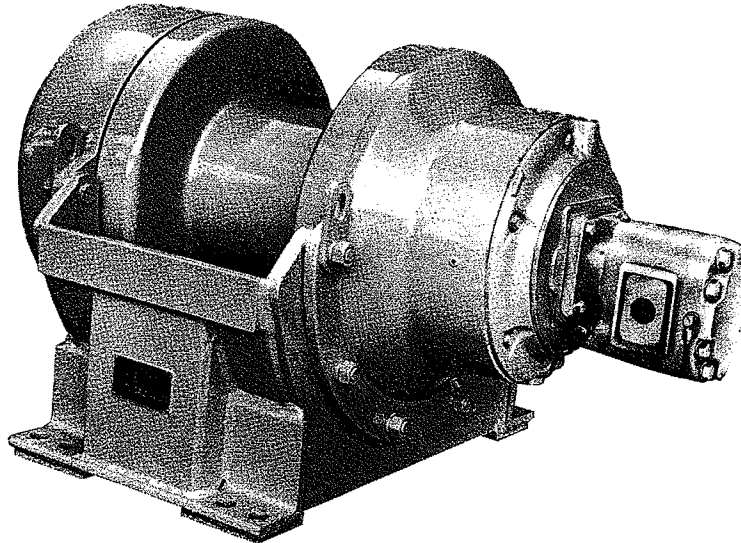

- Equal speed.
- Externally mounted hydraulic motor for installation flexibility.
- Automatic brake, spring applied, hydraulically released, for smooth operation.
- Anti-friction bearings used throughout with all parts running in oil to increase component life and maximize efficiency.
- Planetary gearing with optional hydraulic motors provide most efficient use of available horsepower.
- High capacity and A.P.I. specification drum sizes available.
- External brake port connection allows for independent brake release.
- Full load wire rope anchor available for rope sizes up to 1 1/8" diameter.
- Optional free fall available.

EXPLANATION OF MODEL NUMBER

GH50 - 114090 - 00

PRIMARY DRIVE

GH50 - Single Speed
G2H50 - Two Speed

FINAL DRIVE

BLANK - Without Free Fall
F - Controlled & Full Release Free Fall
G - Controlled Free Fall
J - Full Release Free Fall

OVERALL RATIO

Equal Speed

114 - 114:1 (Std. w/Single Speed Motor)
082 - 82.2:1 (Std. w/Two Speed Motor)
057 - 57:1

MOTOR

090 - 9.02 Cu. In. Displacement
110 - 11.03 Cu. In. Displacement
127 - 12.75 Cu. In. (Low) Displacement
6.375 Cu. In. (High) Displacement

DRUM

INCHES	CM
00 - Special	
20 - 12 X 22 X 12	30.5 X 55.9 X 30.5
01 - 12 X 22 X 18	30.5 X 55.9 X 45.7
02 - 12 X 22 X 24	30.5 X 55.9 X 61.0
03 - 12 X 22 X 30	30.5 X 55.9 X 76.2
05 - 20 X 30 X 13	50.8 X 76.2 X 33.0
06 - 20 X 30 X 19	50.8 X 76.2 X 48.3
07 - 20 X 30 X 25	50.8 X 76.2 X 63.5
08 - 20 X 30 X 31	50.8 X 76.2 X 78.7

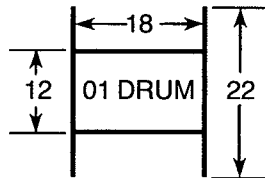

PERFORMANCE GRAPHS

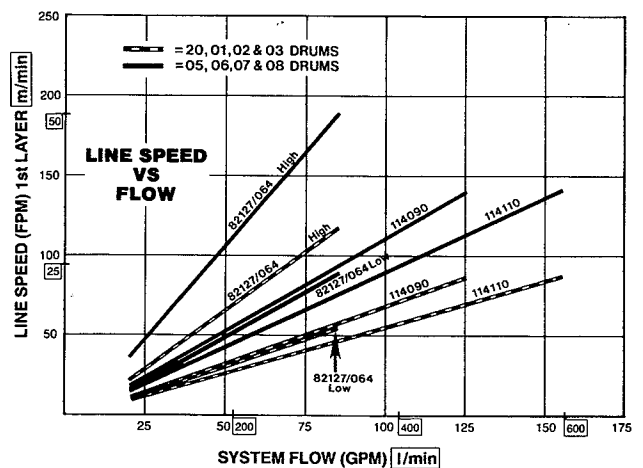
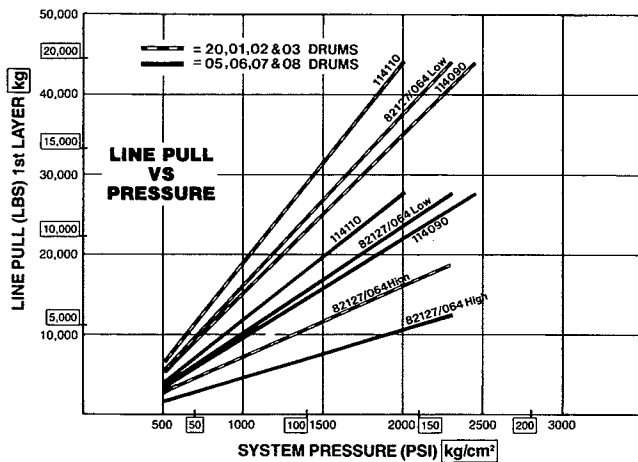

SPECIFICATIONS ARE SUBJECT TO CHANGE WITHOUT NOTICE AND WITHOUT INCURRING OBLIGATION.

GH50 PERFORMANCE

20, 01, 02 & 03 DRUMS

ROPE SIZE IN. (mm)	LAYER	114:1 OVERALL RATIO		82.2:1 OVERALL RATIO				20,01,02 AND 03 DRUMS			
		090 MOTOR 9.02 Cu. In. Disp. 2450 PSI @ 125 GPM (172 Kg/cm ² @ 472 1/min) OR 110 MOTOR 11.03 Cu. In. Disp. 2000 PSI @ 153 GPM (140 Kg/cm ² @ 578 1/min)		127/064 MOTOR 2-SPEED MOTOR 2300 PSI @ 85 GPM (162 Kg/cm ² @ 320 1/min)				ROPE CAPACITY			
				12.75 Cu. In. Disp. Low Speed		6.375 Cu. In. Disp. High Speed		20 Drum	01 Drum	02 Drum	03 Drum
		Line Pull	Line Speed	Line Pull	Line Speed	Line Pull	Line Speed	Ft.	Ft.	Ft.	Ft.
		Lbs.	FPM	Lbs.	FPM	Lbs.	FPM	m	m	m	m
	Kg	m/min	Kg	m/min	Kg	m/min					
7/8 (22)	1	44,000	87	44,000	56	19,670	118	46	69	92	115
		19,960	26.8	19,960	17.0	8,920	36.0	14.2	21.6	28.7	35.4
	2	38,750	98	38,750	63	17,320	134	98	147	197	246
		17,600	30.2	17,610	19.3	7,860	40.9	30.2	45.9	61.1	75.6
	3	34,610	110	34,610	71	15,470	150	156	235	314	392
		15,750	33.9	17,750	21.6	7,020	45.9	48.4	73.1	97.4	120.7
	4	31,270	122	31,270	78	13,970	166	221	332	444	554
		14,200	37.6	14,200	23.9	6,340	50.6	68.5	103.3	137.8	170.4
	5	28,500	134	28,500	86	12,740	183	292	439	586	732
		12,930	40.8	12,930	26.2	5,780	55.8	89.0	133.8	178.6	223.1
1 (25)	1	44,000	87	44,000	57	19,670	119	40	61	81	102
		19,960	26.8	19,960	17.0	8,920	36.3	12.6	19.1	25.3	31.4
	2	38,140	101	38,140	65	17,040	138	87	131	175	219
		17,340	31.1	17,340	19.8	7,730	41.7	27.1	40.0	54.2	67.7
	3	33,660	114	33,660	74	15,040	156	140	211	281	352
		15,320	35.2	15,320	22.8	6,820	47.5	43.8	66.0	87.2	108.8
	4	30,110	128	30,110	82	13,450	175	199	300	400	501
		13,730	39.2	13,730	25.0	6,100	53.0	62.3	93.7	123.7	154.8
	5	27,420	141	27,420	91	12,170	193	264	398	531	665
		12,440	43.0	12,440	27.7	5,520	58.8	80.5	121.3	161.8	202.7
1 1/8 (29)	1	44,000	88	44,000	57	19,670	121	36	54	73	91
		19,960	27.1	19,960	17.3	8,920	36.8	11.0	16.6	21.9	27.4
	2	37,570	103	37,570	67	16,790	142	78	118	158	198
		17,010	32.1	17,010	20.4	7,620	43.2	23.8	36.1	47.5	59.7
	3	32,770	119	32,770	76	14,650	162	127	191	256	321
		14,820	36.7	14,820	23.3	6,650	49.5	38.7	58.6	77.1	96.6
	4	29,060	134	29,060	86	12,990	183	182	274	367	459
		13,180	40.8	13,180	26.2	5,890	55.8	55.5	83.5	111.9	140.0

PERFORMANCE CONVERSION FACTORS

To calculate Line Pulls and Line Speeds for GH50 winches with Overall Ratios not shown in the charts, use the following formulas.

(114:1 Ratio Line Pull) X 0.721 = 82.2:1 Ratio Line Pull (114:1 Ratio Line Pull) X 0.500 = 57:1 Ratio Line Pull (82.2:1 Ratio Line Pull) X 0.693 = 57:1 Ratio Line Pull	(114:1 Ratio Line Speed) X 1.39 = 82.2:1 Ratio Line Speed (114:1 Ratio Line Speed) X 2.00 = 57:1 Ratio Line Speed (82.2:1 Ratio Line Speed) X 1.44 = 57:1 Ratio Line Speed
---	--

GH50 PERFORMANCE

05, 06, 07 & 08 DRUMS

ROPE SIZE IN. (mm)	LAYER	114:1 OVERALL RATIO		82.2:1 OVERALL RATIO				05,06,07 AND 08 DRUMS				
		090 MOTOR 9.02 Cu. In. Disp. 2450 PSI @ 125 GPM (172 Kg/cm ² @ 472 1/min)		127/064 MOTOR 2-SPEED MOTOR 2300 PSI @ 85 GPM (162 Kg/cm ² @ 320 1/min)				ROPE CAPACITY				
		110 MOTOR 11.03 Cu. In. Disp. 2000 PSI @ 153 GPM (140 Kg/cm ² @ 578 1/min)		12.75 Cu. In. Disp. Low Speed		6.375 Cu. In. Disp. High Speed		05 Drum	06 Drum	07 Drum	08 Drum	
		Line Pull	Line Speed	Line Pull	Line Speed	Line Pull	Line Speed	Ft.	Ft.	Ft.	Ft.	
		Lbs.	FPM	Lbs.	FPM	Lbs.	FPM	m	m	m	m	
	Kg	m/min	Kg	m/min	Kg	m/min						
3/4 (19)	1	27,400	140	27,400	90	12,250	191	95	139	182	225	
		12,430	42.7	12,430	27.4	5,560	81.2	29.0	42.4	55.5	68.6	
	2	25,560	150	25,560	96	11,430	205	197	288	377	467	
		11,600	45.7	11,600	29.4	5,190	62.4	60.0	87.8	114.9	142.3	
	3	23,950	160	23,950	103	10,710	218	306	447	585	725	
		10,870	48.8	10,870	31.3	4,860	66.5	93.3	136.2	178.3	221.0	
	4	22,530	170	22,530	109	10,070	232	422	616	807	999	
		10,230	51.8	10,230	33.4	4,570	70.8	128.6	187.8	246.0	304.5	
	5	21,260	180	21,260	116	9,510	246	545	795	1042	1290	
		9,650	54.9	9,650	35.4	4,320	75.1	166.1	242.3	317.6	393.2	
	6	20,130	190	20,130	123	9,000	260	675	984	1290	1597	
		9,140	57.9	9,140	37.4	4,090	79.1	205.7	299.9	393.2	486.8	
7/8 (22)	1	27,400	141	27,400	91	12,250	192	82	119	157	194	
		12,430	43.0	12,430	27.7	5,560	58.5	25.3	36.0	47.2	59.7	
	2	25,290	152	25,290	98	11,300	208	171	248	327	405	
		11,490	46.3	11,490	29.9	5,140	63.4	52.7	75.0	98.4	124.7	
	3	23,470	164	23,470	106	10,490	224	267	388	510	632	
		10,670	50.0	10,670	32.2	4,770	68.2	82.3	117.0	153.6	194.5	
	4	21,900	176	21,900	113	9,790	240	370	538	706	875	
		9,960	53.6	9,960	34.6	4,450	73.1	113.7	162.1	213.0	269.1	
	5	20,520	188	20,520	121	9,170	257	480	698	916	1135	
		9,340	57.0	9,340	36.8	4,180	78.0	147.2	210.3	276.4	349.0	
	1" (25)	1	27,400	141	27,400	92	12,250	193	72	105	138	171
			12,430	43.0	12,430	27.7	5,560	58.7	22.2	32.6	42.7	53.0
2		25,030	155	25,030	100	11,190	211	151	220	289	358	
		11,370	47.2	11,370	30.5	5,090	64.5	46.0	68.3	89.3	110.9	
3		23,030	168	23,030	109	10,290	230	237	345	453	562	
		10,470	51.2	10,470	33.0	4,680	70.0	73.1	107.0	140.2	173.7	
4		21,320	182	21,320	117	9,530	248	330	480	631	782	
		9,700	55.5	9,700	35.7	4,340	75.5	101.8	148.7	195.1	241.7	
5		19,850	195	19,850	126	8,870	267	430	625	822	1018	
		9,040	59.4	9,040	38.2	4,050	80.8	132.6	193.5	253.9	314.5	

Controlled or full release free fall option limits the winch load holding capacity to 1/3 the winch rating.

SPECIFICATIONS ARE SUBJECT TO CHANGE WITHOUT NOTICE AND WITHOUT INCURRING OBLIGATION.

DIMENSIONAL DATA

Dimensions in parenthesis are in millimeters.

Drum	A	B	C	D
20	12 (305)	22 (560)	12 (305)	12.50 (317)
01	12 (305)	22 (560)	18 (457)	18.50 (470)
02	12 (305)	22 (560)	24 (610)	24.50 (622)
03	12 (305)	22 (560)	30 (762)	30.50 (775)
05	20 (508)	30 (762)	13.2 (335)	12.50 (317)
06	20 (508)	30 (762)	19.2 (488)	18.50 (470)
07	20 (508)	30 (762)	25.2 (640)	24.50 (622)
08	20 (508)	30 (762)	31.2 (792)	30.50 (775)

Motor	E	F
090	9.00 (228)	5.38 (136)
110	9.50 (241)	5.63 (143)
127 (2-Speed)	15.00 (381)	8.56 (217)

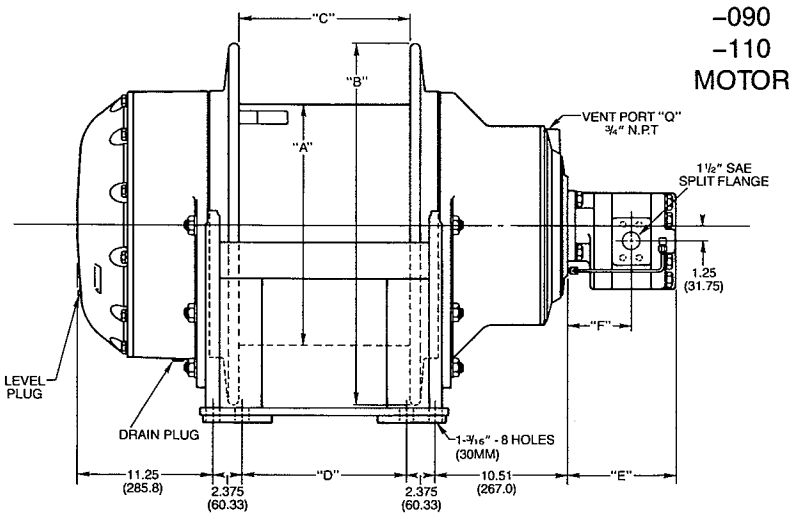

-090
-110
MOTOR

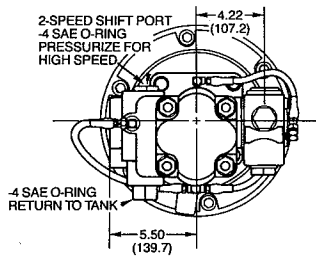

-127 MOTOR
(2-Speed)

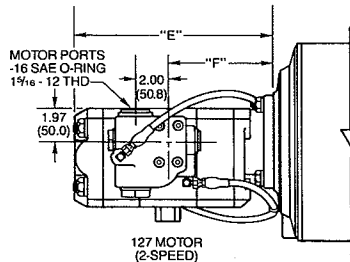

PRESSURIZE THIS PORT TO PAY-OUT CABLE. PRESSURIZE THIS PORT TO HAUL-IN CABLE.

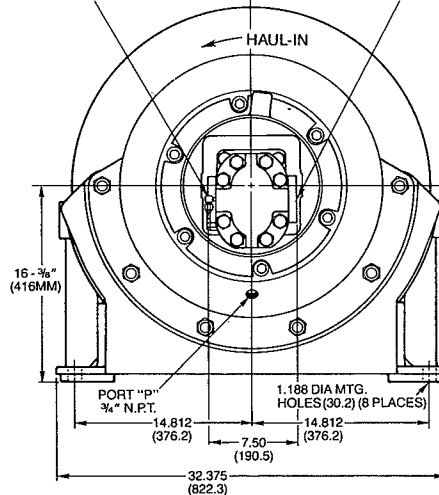

**FREE
FALL
OPTION**

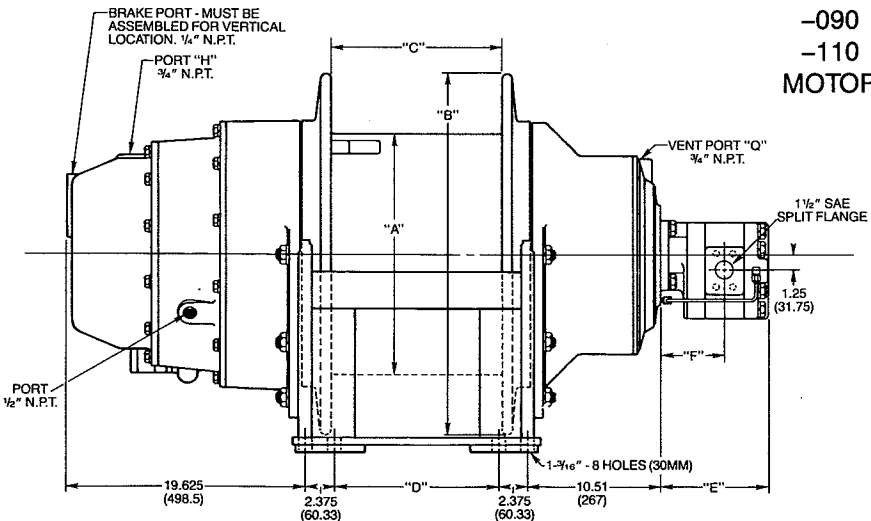

-090
-110
MOTOR

HYDRAULIC CIRCUIT

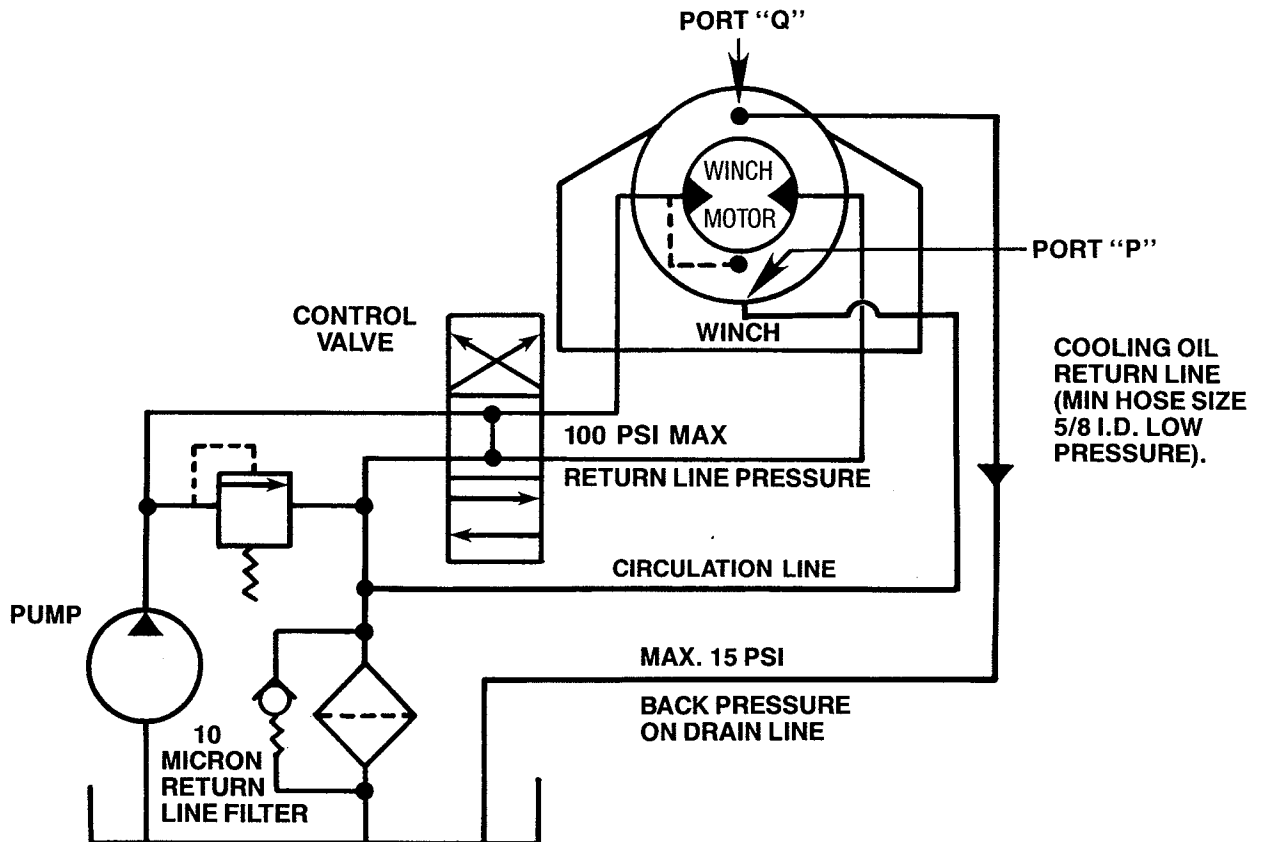

WINCH INSTALLATION NOTES:

1. Vent Port "Q" should be located as close as possible to the "top dead center" of the winch, based on the mounting position of the winch.

2. When mounting the winch, use all eight (8) mounting holes and grade eight (8) bolts and nuts. Evenly tighten nuts to 800 lb.-ft. (111 kg-m) torque, lubricated with 30W motor oil.

It is important that the winch is mounted on a surface that will not flex when the winch is in use, which may cause binding of the gear train. Binding in the gear train will result in accelerated wear and heat. Also, the mounting surface should be flat within 0.020" (0.51mm).

As a final installation test, check clearance between the drum and end housings at two (2) locations around the winch. The clearance should be equal within 0.010" (0.25 mm). Repeat test for each side of winch. Left and right hand sides need not equal each other. If necessary, install shims under winch mounting pads to achieve even mounting.

3. The hydraulic lines and components that operate the winch should be of sufficient size to assure minimum back pressure at the winch.

The winch directional control valve must be a three position four-way valve with a motor spool such that when the valve is in the center position, both work ports are open to tank (open center, open port).

Haul-in or hoisting direction is clockwise when viewed from the final drive (non-motor) end of the winch. Internal oil circulation is standard.

Gearmatic®

PACCAR WINCH DIVISIONS

P.O. BOX 547 • BROKEN ARROW, OK 74013
PHONE: (918) 251-8511 • FAX: (918) 258-4822