

FR3C SERIES

POWER TAKE-OFF FOR THE FORD TORQSHIFT



THE PROVEN LEADER IN DURABILITY

Muncie Power's FR3C power take-off gives you the maximum torque available from the F-650 and F-750 with the Ford TorqShift transmission and a keyed shaft output. Our PTO utilizes a one-piece housing design with forced lubrication for increased durability and simplified installation. The FR3C incorporates integral mobile or stationary functions and a higher torque capacity of 237 lbs.ft.



KEY FEATURES

- Using patented technology
- Utilizes maximum torque available from Ford TorqShift transmission
- Higher torque capacity of 237 lbs.ft.
- One-piece housing, few leak points
- Complete integrated wiring harnesses
- Keyed shaft output
- Enhanced gear set

DIMENSIONS

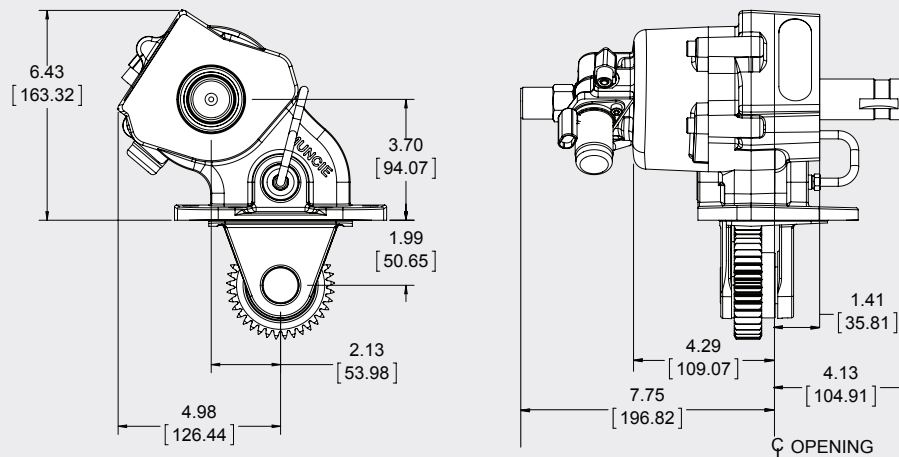

PTO TORQUE & HORSEPOWER RATINGS

SPEED RATIO	INTERMITTENT HP@ 1,000 RPM	INTERMITTENT TORQUE LBS.FT.	CONTINUOUS TORQUE LBS.FT.	INTERMITTENT (KW)@ 1,000 RPM	INTERMITTENT TORQUE (NM)	CONTINUOUS TORQUE (NM)
09	45	237	166	(34)	(321)	(225)

Approximate Weight: 31 lbs. (14.1 Kg.)

MODEL NUMBER CONSTRUCTION

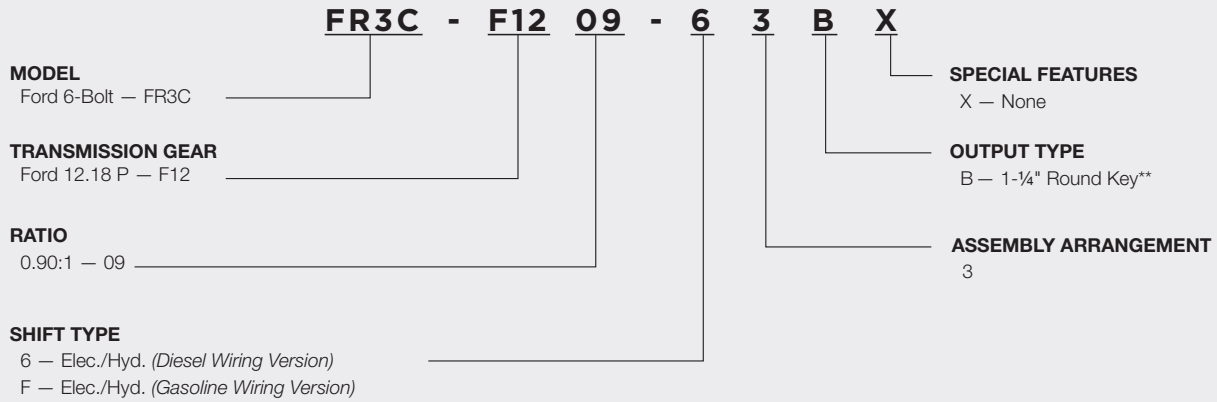

** Driveline output is not recommended on 4x4 Chassis.



A Member of the Interpump Group

MP16-01 (Rev. 12-17)

201 East Jackson Street • Muncie, Indiana 47305
 800-367-7867 • Fax 765-284-6991 • info@munciepower.com • www.munciepower.com
 Specifications are subject to change without notice. Visit www.munciepower.com
 for warranties and literature. All rights reserved. © Muncie Power Products, Inc. (2016)